

LOC	DIST	REVISIONS			
P	LTR	DESCRIPTION	DATE	DWN	APVD
IR	-	A	INITIAL RELEASE	28DEC 2012	PKS RRP

NOTES:

1. CONTINUOUS STRIP ON REELS
2. WIRE RANGE: 18-14 AWG [0.8-2.0 SQ.mm]
3. INSULATION RANGE: $\varnothing 2.67-4.32$
4. FEED [PITCH] : 18.0

5 AMP LOGO

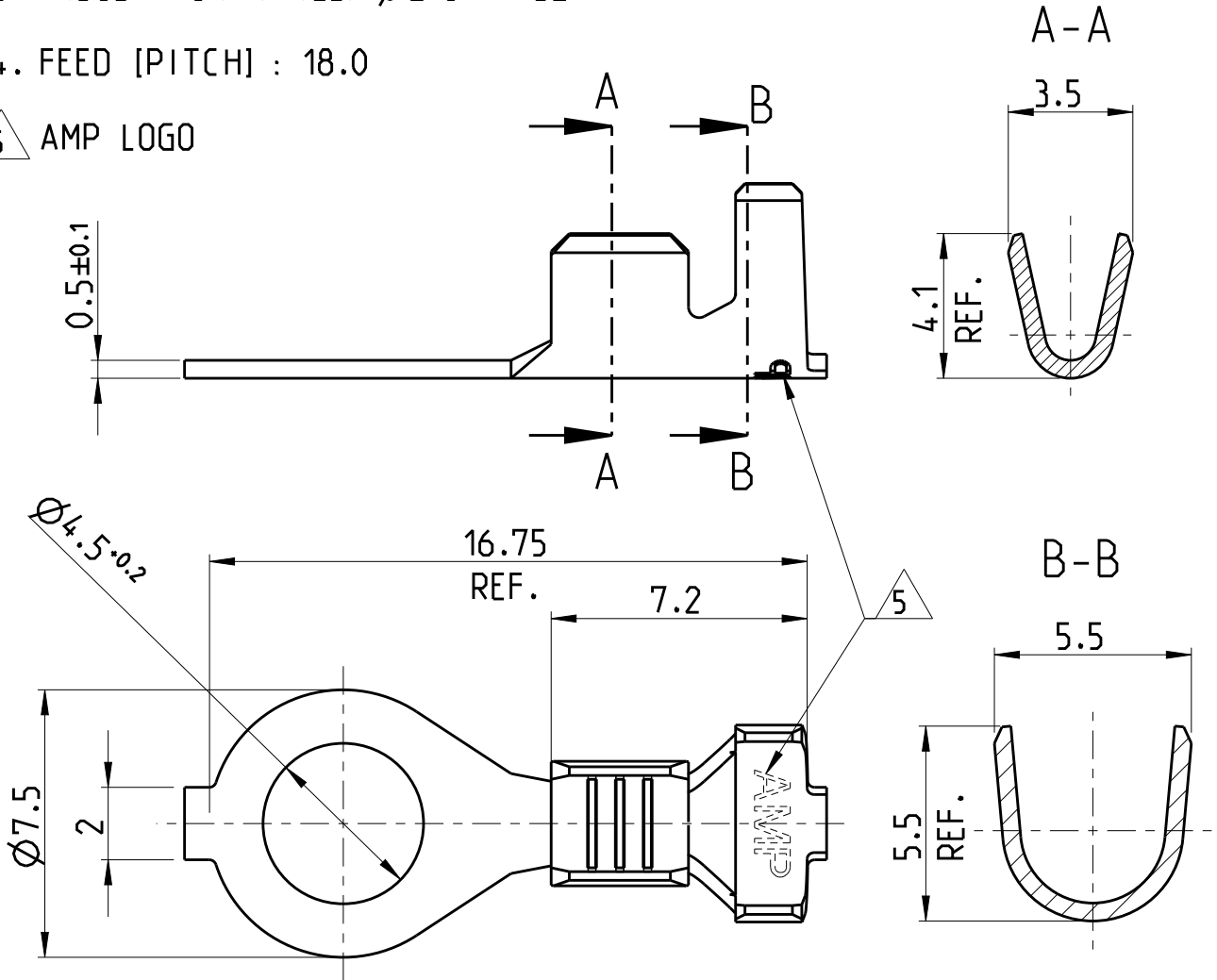

PRE-TIN; 1-3 μ m	BRASS	2178505-3
FINISH	MATERIAL	PART NO

2012
 RELEASED FOR PUBLICATION
 ALL RIGHTS RESERVED.
 COPYRIGHT 2012

DIMENSIONS: mm	DWN SENTHIL 28DEC 2012	MATERIAL SEE TABLE	FINISH SEE TABLE
TOLERANCES UNLESS OTHERWISE SPECIFIED:	CHK SENTHIL 28DEC 2012		
0 PLC ± 0.2	APVD RAJENDRA 28DEC 2012		
1 PLC ± 0.2	PRODUCT SPEC	NAME RING TONGUE TERMINAL	
2 PLC ± 0.1	-	STUD DIA. 4.5; M4	
3 PLC ± 0.05	APPLICATION SPEC	SIZE A 4	CAGE CODE 00779
4 PLC \pm	114-2084	DRAWING NO C-2178505	RESTRICTED TO -
ANGLES \pm	WEIGHT 0.4g approx.	Customer Drawing	
		SCALE 5:1	SHEET 1 OF 1
			REV A